

Hardie™ Panel Conceal System

Installation Guide



Mechanical concealed fixing with
Hardie™ Panel Conceal System



JamesHardie™



Content

01	Mechanical concealed fixing with Hardie™ Panel Conceal System	3	03	Cladding of soffits	18
1.1	Introducing the Hardie™ Panel Conceal System	3	3.1	Row and fastener spacing	18
1.2	Tools and Components – powered by KEIL®	4	3.2	Technical Details	19
1.3	System Description	5	04	Wind Load	20
1.4	Components for mechanical concealed fixing	6			
02	Installation of Hardie® Panel facade cladding with the Hardie™ Panel Conceal System	10			
2.1	Preparation	10			
2.2	Mounting the Hardie™ Panel Conceal Anchor	12			
2.3	Technical Details	14			



01 Mechanical concealed fixing with Hardie™ Panel Conceal System

1.1 Introducing the Hardie™ Panel Conceal System

The Hardie™ Panel Conceal System is a system for mechanical concealed fixing. It is powered in collaboration with the company KEIL, that is known for their reliable products for mechanical hidden fixing.

The system consists of the Hardie™ Panel Conceal Anchor + Screw, which is a specially developed version of the KARL Anchor by KEIL® in 7.5 mm depth fitting the 11 mm Hardie® Panel and Hardie® Architectural Panel facade panels and an M6 screw in 10.5 mm, suitable for most hanger systems available on the market.

The Hardie™ Panel Conceal Stopping Drill and Hardie™ Panel Conceal Setting Tool allow an easy and fast application of the Hardie™ Panel Conceal Anchor. The anchor can be set in Hardie® Panel and Hardie® Architectural Panel facade panels without expansion pressure in just a few steps. The form-fit connection prevents stresses and therefore cracks, while achieving high pull-out values.

1.2 Tools and Components – powered by KEIL®

Hardie™ Panel Conceal Stopping Drill



The stopping drill is set for a depth of 7.5 mm.
 Drill hole depth = 8.5 mm.
 Drill hole diameter = 7.1 mm.
 The use of this stop drill guarantees the correct drill hole depth.
 Service Life: ~1 500 holes

Hardie™ Panel Conceal CNC / Replacement Drill



Suitable for CNC machines and as a replacement drill for the Hardie™ Panel Conceal Stopping Drill.
 Service Life: ~1 500 holes

Hardie™ Panel Conceal Test Mandrel



7/7.5 mm
 For checking the required drill hole diameter.

Hardie™ Panel Conceal Setting Tool



For spreading the Anchor in the drill hole, suitable for the specific depth of 7.5 mm
 Service Life: minimum 1 000 setting processes

Set Hardie™ Panel Conceal Anchor + Screw 10.5 mm



Self-undercutting Anchor with hexagon head for WAF 9.
 Setting depth 7.5 mm
 M6 hexagon head screw with locking teeth in 10.5 mm length.
 Stainless Steel A4

Set Hardie™ Panel Conceal Anchor + Screw – Project customized length



Self-undercutting Anchor with hexagon head for WAF 9.
 Setting depth 7.5 mm
 M6 hexagon head screw with locking teeth in project customized length – only on special request.
 Stainless Steel A4

Set Hardie™ Panel Conceal Anchor + Bolt and Nut



Self-undercutting Anchor with hexagon head for WAF 9.
 Setting depth 7.5 mm
 Stepped threaded bolt suitable for setting depth 7.5 mm with hexagon socket and matching nut with locking teeth.
 Stainless Steel A4

1.3 System Description

Hardie® Panel and Hardie® Architectural Panel facade panels in 11 mm thickness installed with mechanical concealed fixing are a durable, qualitative and neat solution for facade design in new built and renovations.

The installation of the self-undercutting Hardie™ Panel Conceal Anchor at the backside of the facade panel ensures to have a facade without any visible fixings.

Each facade panel must be applied to suitable sub frames without technical restraint with a minimum of four fixing points which are usually arranged in a rectangular pattern, using single or double hangers. Once the hangers are applied to the backside of the facade panel, it is being hang in the matching horizontal support profiles and fixed at one point.

The load is transferred to the substrate via the available substructure variants available on the market. Like the visible fixing options, the substructure consists of wall brackets and vertical L or T profiles. The horizontally aligned hanger support profiles are attached to this basic substructure. The facade panels can be hooked into the hanger support profiles using the hangers attached to the rear of the panel. Adjusting screws, usually located in the outer hangers of the top row of hangers, enable fine alignment of the facade panel. Horizontal displacement of the panel is achieved using special securing brackets or by screwing in a locking screw. If the stability verification for the transfer of loads requires a higher load-bearing capacity value for the hangers, double hangers (with two Hardie™ Panel Conceal anchors per hanger) can be used instead of single hangers, either partially or over the entire surface.



1.4 Components for mechanical concealed fixing

1. Hardie® Panel or Hardie® Architectural Panel facade panels with a nominal thickness 11 mm

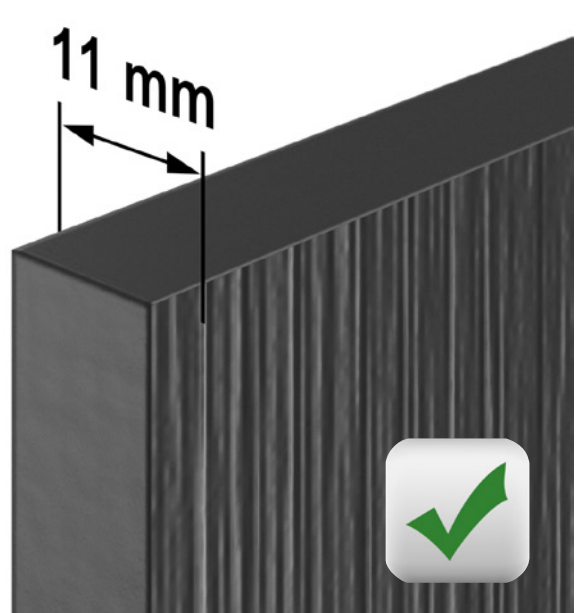
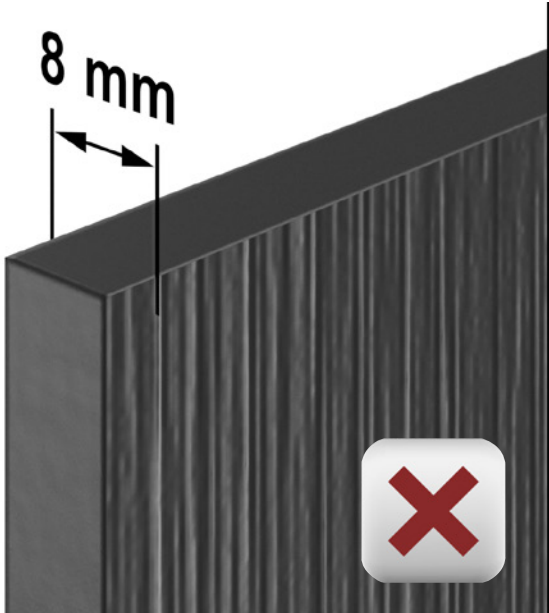

2. Hangers – to be sourced externally/by a third party sub frame manufacturer.

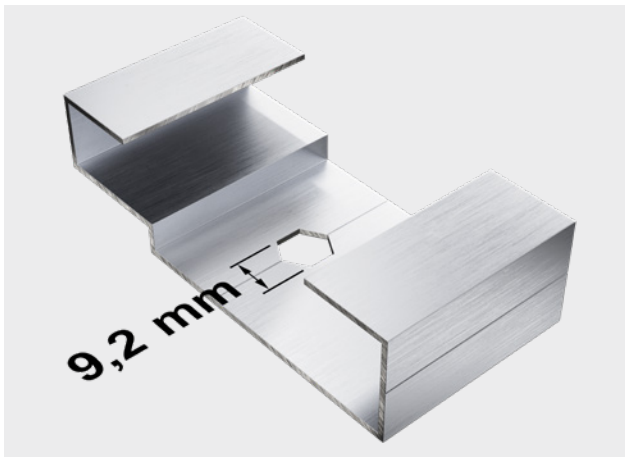

Single Hanger with hexagonal hole

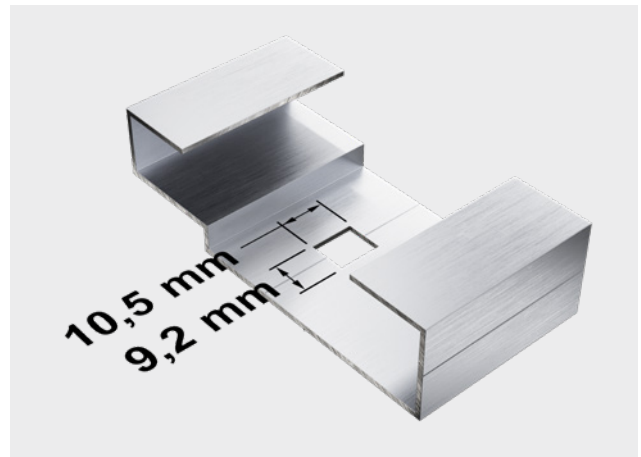

Single Hanger with rectangular hole

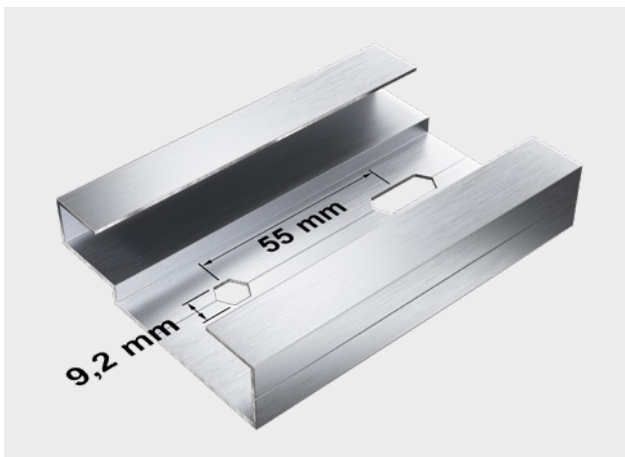

Double Hanger with hexagonal hole

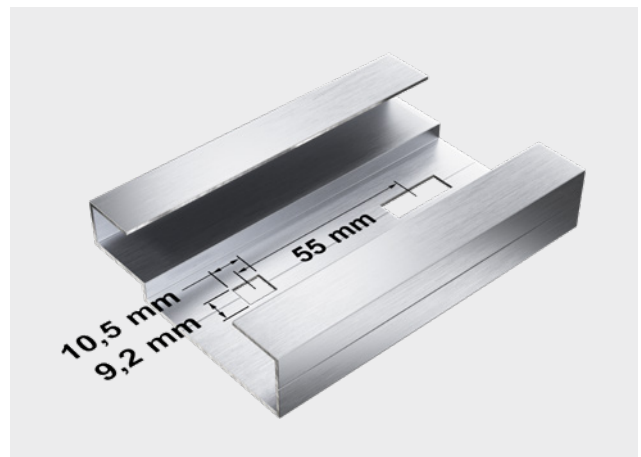

Double Hanger with rectangular hole

**Hanger Type A**

Hanger without additional drilling

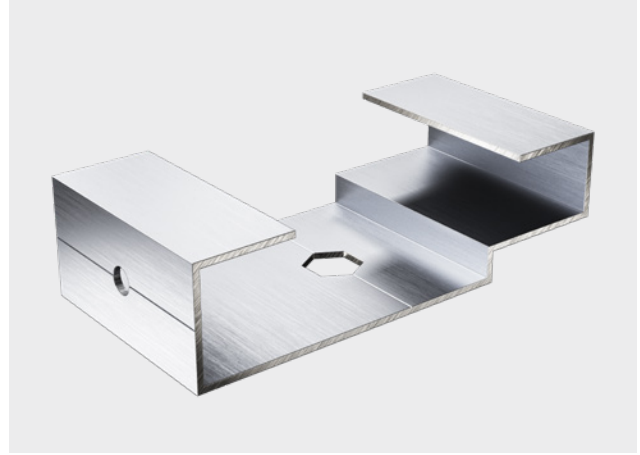
**Hanger Type B**

Leveling Hanger with pre-applied drilling, usually with internal thread, for fine adjustment of the facade panel

**Hanger Type C**

Hanger with pre-applied drilling, usually with internal thread, for fine adjustment of the facade panel and additional hole for setting a locking screw. A fixed point is created when the locking screw is set. As an alternative to the locking screw, side-mounted locking brackets can also be used.

The head of the Hardie™ Panel Conceal anchor is hexagonal in shape and designed for a spanner width of 9mm. This is the baseline for the shape and the height of the punched holes in the hangers. When using double hangers, one punched hole must be designed as a fixed point and the other punched hole as a sliding point. The thermally induced change in length can be ensured via a slotted hole. The slotted hole also makes it easier to attach the hanger.

3. Hardie™ Panel Conceal System

Determination of the correct screw length to match the hangers used

The displacement-controlled expansion of the anchor sleeve requires the screw length to be precisely matched to the hanger used. The thread length of the screw varies depending on the shape of the hanger and its material thickness (case A, B and C). Only the use of matching components makes installation quick, easy and safe. The head of the

Hardie™ Panel Conceal Anchor is three millimetres thick. To ensure a permanent connection, make sure that the Hardie™ Panel Conceal screw digs tightly with its locking teeth into the hangers. A test installation should be carried out to check whether the screwed-in screw fits flush with the tip of the anchor sleeve when the prescribed tightening torque of 2.5 to 4.0 Nm is applied.

Case A

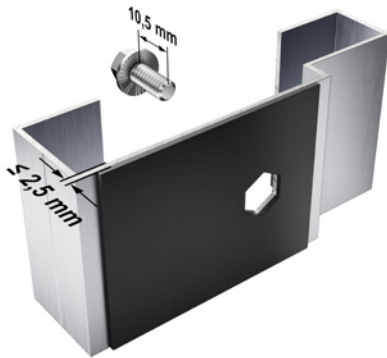

For hangers with a material thickness of 2.5 mm or less, an additional elastic intermediate layer must be used. This can usually be obtained from the manufacturer/supplier of the substructure. The elastic intermediate layer compensates for the thickness difference between the hanger and the anchor head. compared to the anchor head. The Hardie™ Panel Conceal screw with a standard length of 10.5 mm is used for screwing.

Case B

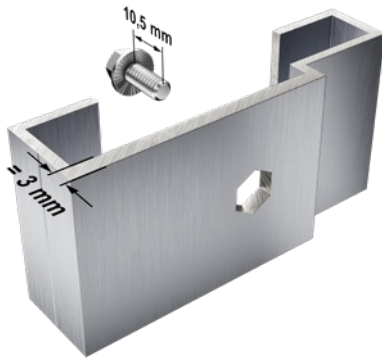

For hangers with a material thickness of exactly three millimetres, the Hardie™ Panel Conceal screw with a standard length of 10.5 mm is used. An elastic intermediate layer must not be used.

Case C



Hangers with a material thickness greater than three millimetres or if the shape of the hangers results in a greater installation height than three millimetres, the screw length must be matched to the clamping thickness of the hanger. The correct screw length results from the length of the Hardie™ Panel Conceal screw 10.5 mm and the hanger clamping thickness minus the head thickness of the Hardie anchor.

Example: The shape of the hanger results in an installation height of 4.5 mm. The length of the screw must therefore be 12 mm.

The design of the facade panels with regard to the centre distances and spacing of the fasteners must be based on a project-specific structural analysis. Individual dimensioning enables the variation of fastener spacing in vertical and horizontal directions. If the stability verification for the transfer of loads requires a higher load-bearing capacity value for the hangers, double hangers can be used partially or over the entire surface instead of single hangers. Fine alignment of the facade panel can be carried out using the hangers types B and C.

Note: In the diagram, the different hangers types A, B and C are assigned to the fixing points as examples. The arrangement of the fixing points must be carried out by a licensed engineer planner.

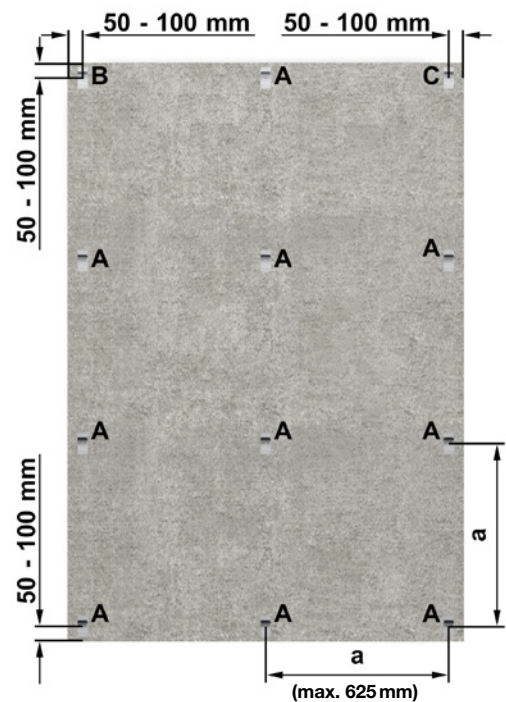
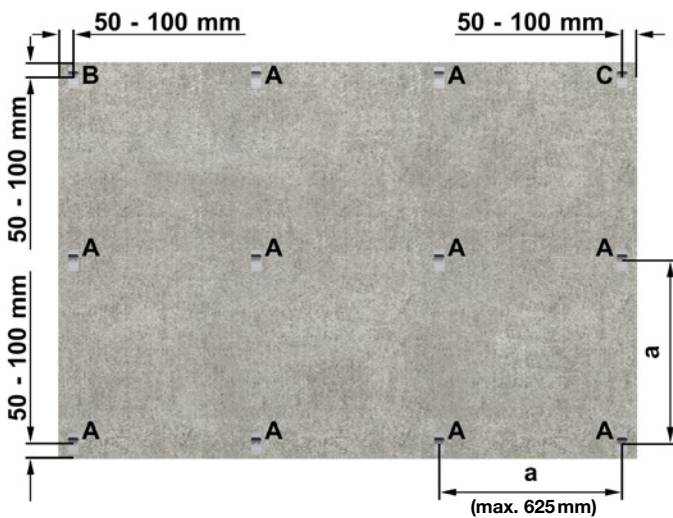

02 Installation of Hardie® Panel facade cladding with the Hardie™ Panel Conceal System

2.1 Preparation

For general storage and handling instructions, please consult the generic Hardie® Panel and Hardie® Architectural Panel Installation Guide.

The fabrication process it is advised to be done at a fabricator shop with CNC machine to grant the right quality.



The facade panels must lie on a flat, clean and pressure-resistant surface in order to drill a hole and install the Hardie™ Panel Conceal Anchor correctly. Bending of the Hardie® Panel must be avoided. A thin layer of foam can be used to protect the surface. However, the use of thicker, soft protective layers is not recommended.

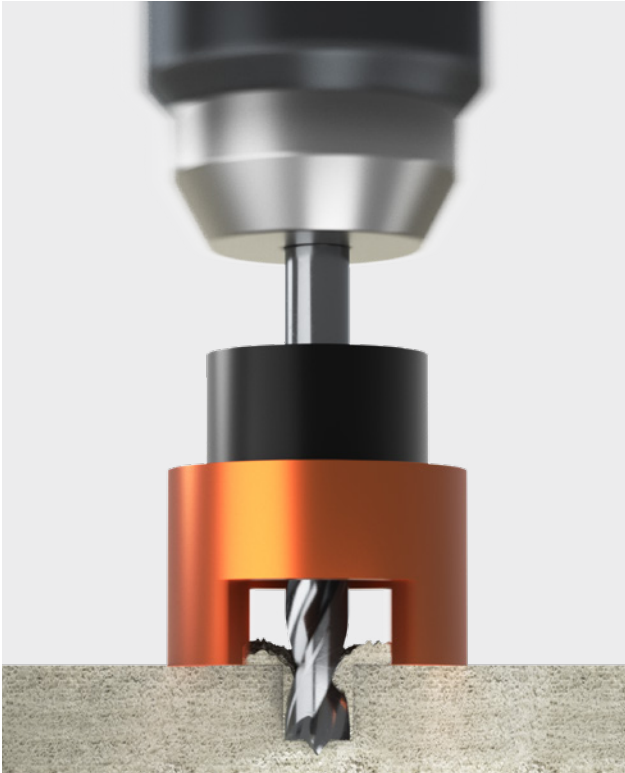

CNC Fabrication:

The fabrication process it is advised to be done at a fabricator shop with CNC machine to grant the right quality.

The drill holes can be created using milling tools on CNC-controlled machines. The drill hole must then be cleaned, e.g. by vacuuming with a Hoover. A rotation speed of max. 5000 1/min is recommended

The anchor sleeve can only be installed correctly if the drill hole is accurate.

Manual Fabrication

Any pre-drilling should happen under workshop conditions, that can also be created on site.

A cylindrical blind hole must be applied on the rear side of the facade panel using a Hardie™ Panel Conceal stop drill. The Hardie™ Panel Conceal stop drill is matched to the setting depth of the Hardie™ Panel Conceal anchor.

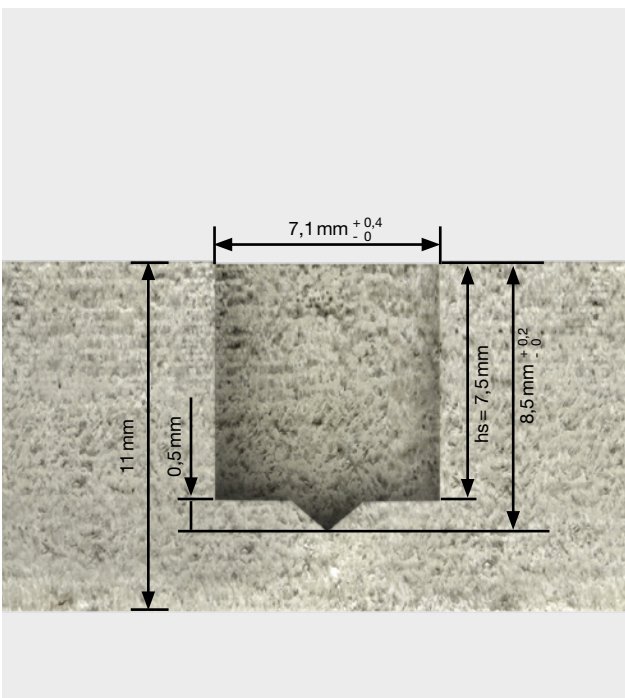

The correct drill hole geometry (drill hole depth = $8,5 \text{ mm} \pm 0,2$ / drill hole diameter = $7,1 \text{ mm} \pm 0,4$) must be checked in accordance with the national approvals, whereby as a rule 1 % or every 100th drill hole must be checked. However, we recommend checking one drill hole per panel in order to minimise rejects in the event of deviations.

The Hardie™ Panel Conceal test mandrel or a caliper gauge can be used to check the drill hole diameter.

The drill hole depth must be determined using a suitable tool, e.g. a caliper gauge. The fabricator is responsible for documenting the test. The date of processing, the batch numbers of the anchors used, the tools and measuring equipment used and the measurement results should be documented and kept for at least the duration of the statutory warranty.

2.2 Mounting the Hardie™ Panel Conceal Anchor

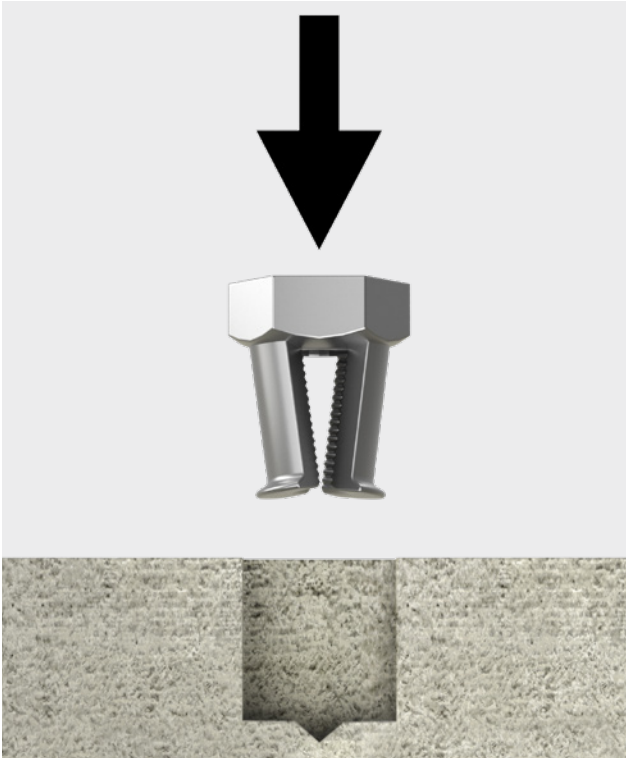

When delivered, the anchor sleeve is compressed in the lower area. The Hardie™ Panel Conceal anchor is inserted into the drill hole in this compressed state.

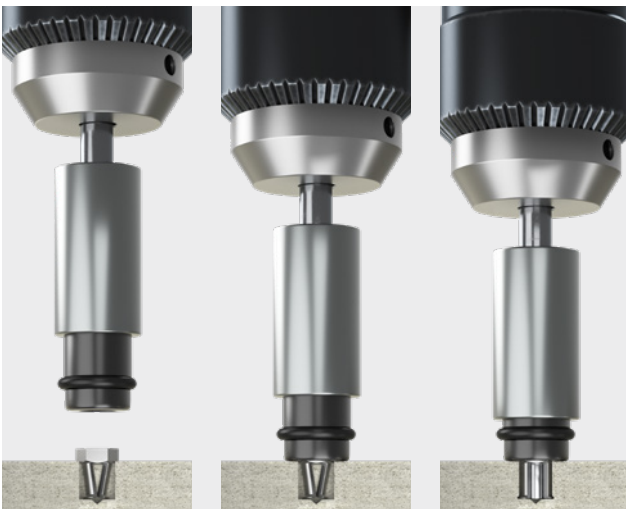

The Hardie™ Panel Conceal Setting tool is clamped in a suitable screwdriver (≥ 1000 rpm) and placed on the head of the anchor sleeve. Start by getting the screwdriver up to the full speed before firmly pressing downwards. During this process the anker sleeve is spread by the setting tool in a rotating manner and cuts the undercut drill hole itself. When the lower stop point of the setting tool is reached, the rotating movement can be stopped and the setting tool can be removed from the anchor sleeve.



The hanger is now placed over the head of the anchor sleeve. The Hardie™ Panel Conceal screw or the Hardie™ Panel Conceal bolt is screwed in with light pressure on the hanger (to lock the anchor). The locking teeth of the screw or nut dig into the panel hanger as a screw lock.

After installation, the undercut anchor sits in the drilled hole without expansion pressure, this means the hanger can be turned with a certain amount of force.

The tightening torque of the screw or bolt/nut is 2.5 to 4 Nm.

Note: If the appropriate Hardie™ Panel Conceal screw or Hardie™ Panel Conceal bolt is used with a defined clamping thickness, the screw-in depth is always correct. Installation is then quick, easy and secure. The screwed-in Hardie™ Panel Conceal screw or Hardie™ Panel Conceal bolt fits flush with the tip of the anchor sleeve. This must be checked before prior to each installation.



The facade panels are hung from the bottom upwards. This allows fine alignment to be carried out via the hangers types B and C attached to the top row of hangers. This also makes it possible to set the fixed point via hanger type C, using the locking screw to be screwed in.

If the facade is to be simply dismantled and re-installed, locking plates matched to the hanger profile should be used to create the fixed points instead of screwed hangers.

2.3 Technical Details

I. Horizontal Gap

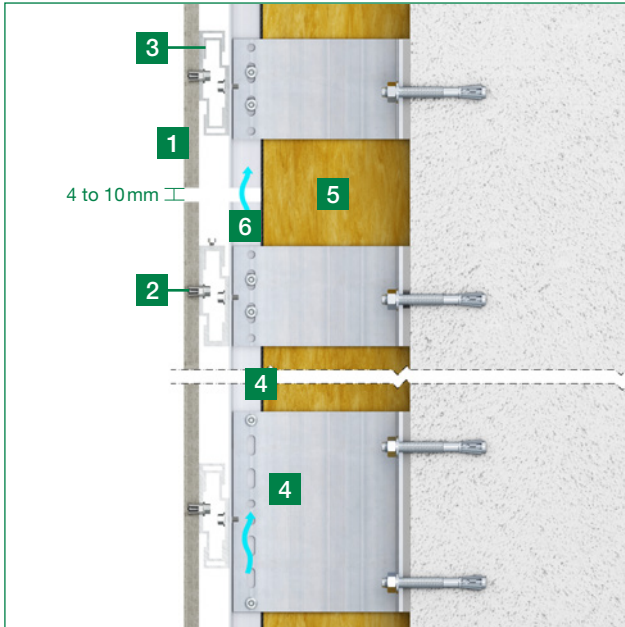

- 1 Hardie® Panel or Hardie® Architectural Panel in 11 mm
- 2 Hardie™ Panel Conceal Anchor and Screw
- 3 hanger and horizontal aluminium profile
- 4 Wall bracket and vertical aluminum support profile (material thickness minimum 2.0 mm)
- 5 Insulation
- 6 Ventilation area

If the facade is to be simply dismantled and re-installed, the fixed points must be created using metal sheets matched to the hanger support profiles.

II. Outside corner

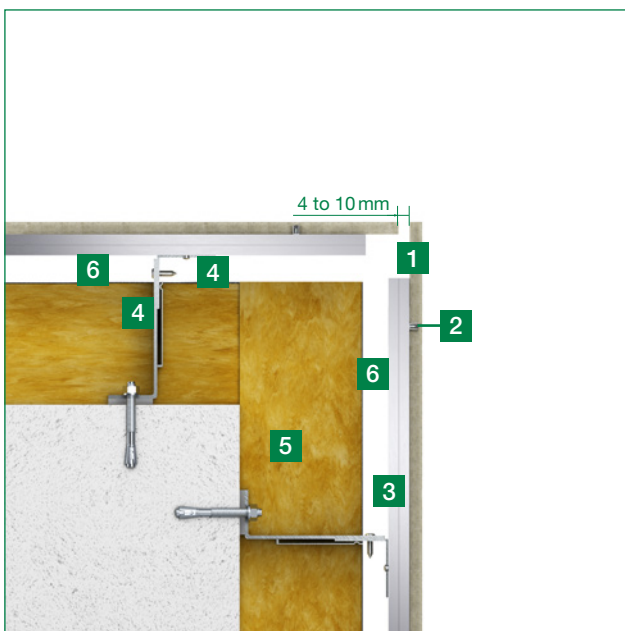

- 1 Hardie® Panel or Hardie® Architectural Panel in 11 mm
- 2 Hardie™ Panel Conceal Anchor and Screw
- 3 Horizontal aluminium profile
- 4 Wall bracket and vertical aluminum support profile (material thickness minimum 2.0 mm)
- 5 Insulation
- 6 Ventilation area

The maximum edge distance for the Hardie™ Panel Conceal anchor is 100 mm. If desired, the vertical joint can also be backed with suitable profiles.

III. Inside Corner



- 1 Hardie® Panel or Hardie® Architectural Panel in 11 mm
- 2 Hardie™ Panel Conceal Anchor and Screw
- 3 Horizontal aluminum profile
- 4 Wall bracket and vertical aluminum support profile (material thickness minimum 2.0 mm)
- 5 Insulation
- 6 Ventilation area

The maximum edge distance for the Hardie™ Panel Conceal anchor is 100 mm. If desired, the vertical joint can also be backed with suitable profiles.

IV. Window reveal / Concealed fixing



- 1 Hardie® Panel or Hardie® Architectural Panel in 11 mm
- 2 Hardie™ Panel Conceal Anchor and Screw
- 3 Horizontal aluminium profile
- 4 Suitable window connection profile
- 5 Wall bracket and vertical aluminum support profile (material thickness minimum 2.0 mm)
- 6 Insulation
- 7 Ventilation area

There are many options for attaching window reveal panels. Concealed fixing can be realised using hangers similar to the facade or using special reveal brackets, which can be obtained from the suppliers of the sub frame.

With visible fixings

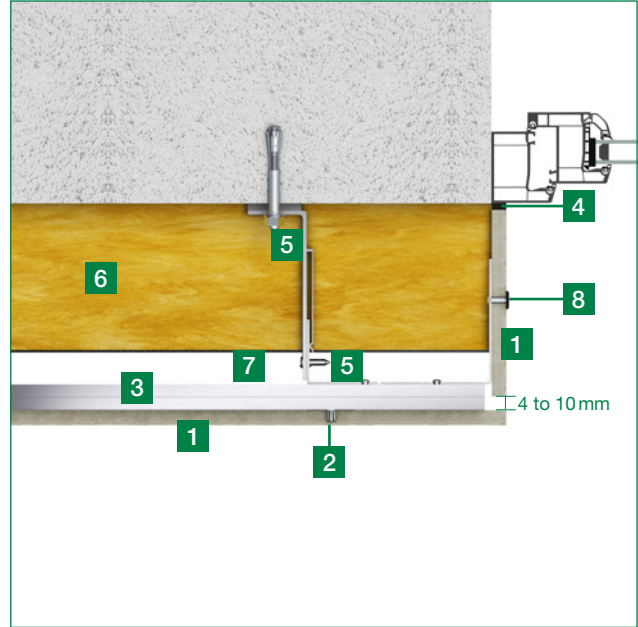

- 1 Hardie® Panel or Hardie® Architectural Panel in 11 mm
- 2 Hardie™ Panel Conceal Anchor and Screw
- 3 Horizontal aluminium profile
- 4 Permanently elastic sealing tape
- 5 Wall bracket and vertical aluminum support profile (material thickness minimum 2.0 mm)
- 6 Insulation
- 7 Ventilation area
- 8 Hardie™ Panel Rivet (for aluminum substructure)

The reveal strips can also be fixed visibly. Suitable fasteners are Hardie™ Panel rivets or Hardie™ Panel screws for aluminum or steel subframes. The connection to the window can be made either with an open joint or with a suitable aluminum connection profile, e.g. with the Hardie™ VL Plank internal corner profile.

V. Window Lintel

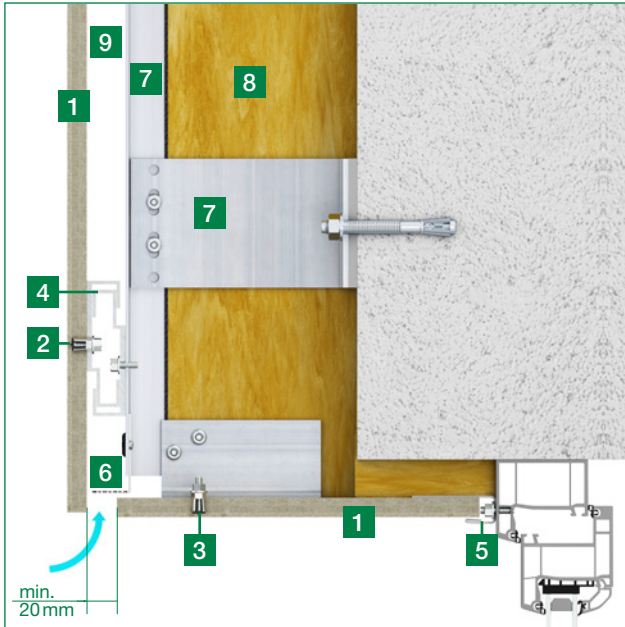

- 1 Hardie® Panel or Hardie® Architectural Panel in 11 mm
- 2 Hardie™ Panel Conceal Anchor and Screw
- 3 Hardie™ Panel Conceal bolt and nut
- 4 Hanger and horizontal aluminium profile
- 5 Suitable window connection profile (e.g. Hardie™ VL Plank internal corner profile)
- 6 Ventilation profile
- 7 Wall bracket and vertical aluminum support profile (material thickness minimum 2.0 mm)
- 8 Insulation
- 9 Ventilation area

The window lintel can also be concealed or visible. Concealed fixing in particular offers several options depending on the respective building situation. A ventilation gap of at least 20 mm must be planned to ensure adequate rear ventilation. To prevent small animals from entering, this gap must be covered with a ventilation grille.

VI. Window sill

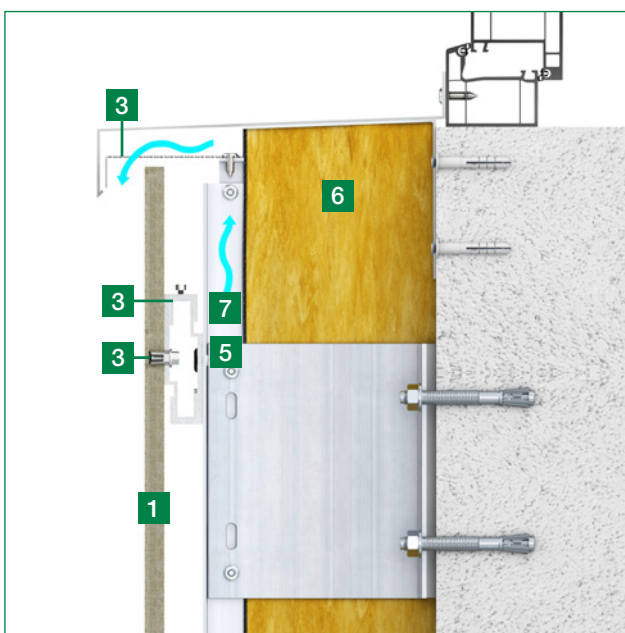

- 1 Hardie® Panel or Hardie® Architectural Panel in 11 mm
- 2 Hardie™ Panel Conceal Anchor and Screw
- 3 Hanger and horizontal aluminium profile
- 4 Ventilation profile
- 5 Wall bracket and vertical aluminum support profile (material thickness minimum 2.0 mm)
- 6 Insulation
- 7 Ventilation area

To ventilate the facade, the distance between the facade panel and the aluminum window sill should be at least 10 mm or 50 cm² per metre. To avoid soiling, we recommend that the windowsill protrudes at least 30 mm above the facade.

03 Cladding of soffits

3.1 Row and fastener spacing

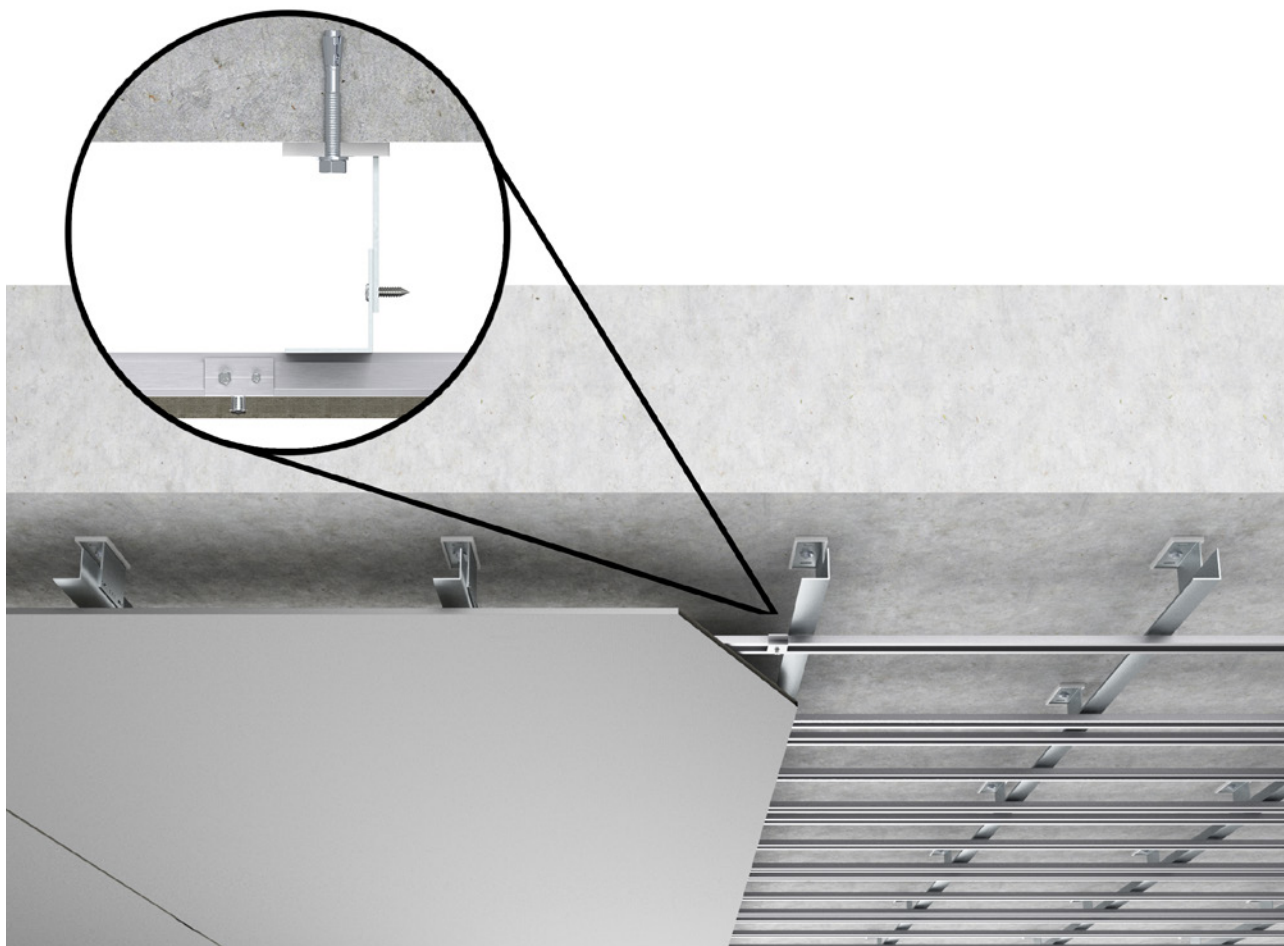

Basic installation instructions for suspended ceilings can be found in the Hardie® Panel and Hardie® Architectural Panel installation instructions.

When planning suspended ceilings, the hanging direction must be taken into account and coordinated with the planned installation sequence.

3.2 Technical Details

I. Soffit to facade connection

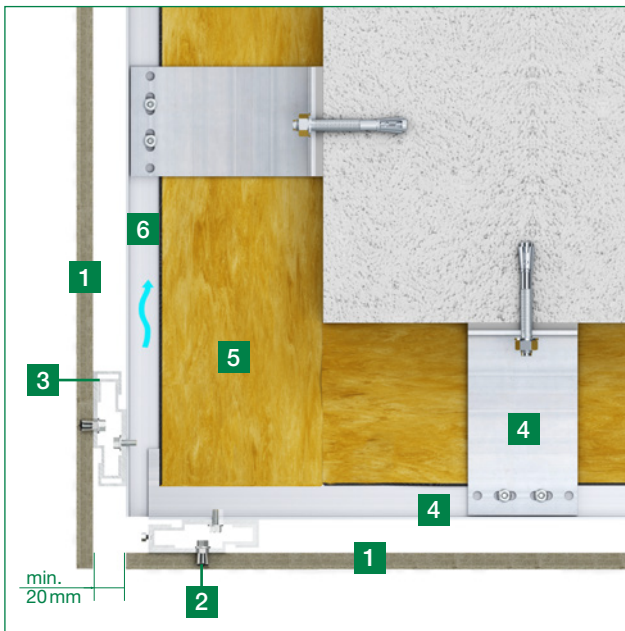

- 1 Hardie® Panel or Hardie® Architectural Panel in 11 mm
- 2 Hardie™ Panel Conceal Anchor and Screw
- 3 Hanger and horizontal aluminium profile
- 4 Wall bracket and vertical aluminium support profile (material thickness minimum 2.0 mm)
- 5 Insulation
- 6 Ventilation area

When planning suspended ceilings, the hanging direction must be observed and coordinated with the planned installation sequence. A ventilation gap of at least 20 mm must be planned to ensure sufficient rear ventilation. This gap must be covered with a ventilation grille to prevent small animals from entering.

II. Connection of soffit to wall

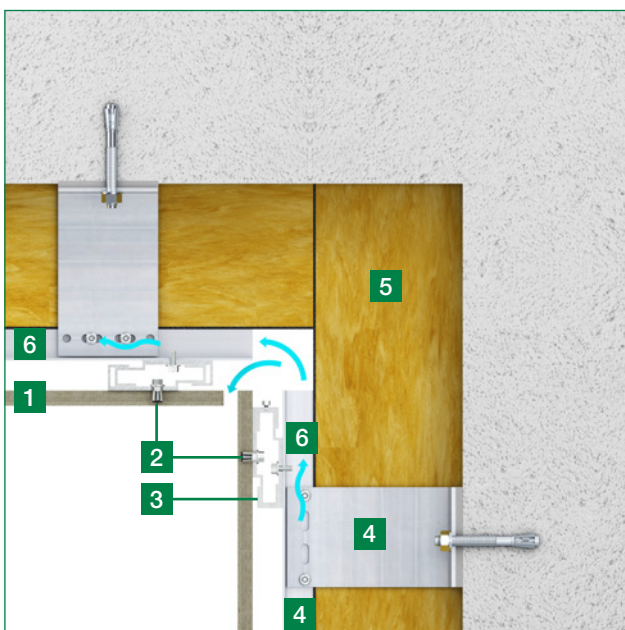

- 1 Hardie® Panel or Hardie® Architectural Panel in 11 mm
- 2 Hardie™ Panel Conceal Anchor and Screw
- 3 Hanger and horizontal aluminium profile
- 4 Wall bracket and vertical aluminium support profile (material thickness minimum 2.0 mm)
- 5 Insulation
- 6 Ventilation area

When planning suspended ceilings, the hanging direction must be observed and coordinated with the planned installation sequence. Depending on the width of the joint at the transition from the suspended ceiling to the wall, a ventilation grille may need to be installed.

04 Wind Load

The following tables are a non-binding aid for the panel format shown (3048 mm × 1220 mm). Calculation must always be provided for the specific project. The fastener spacing is influenced by the

choice of subframes, as well as its bearings and anchoring. The absorption of wind loads according to EN 1991-1-4 and the national appendix must be verified for all components.



Mounted on edge

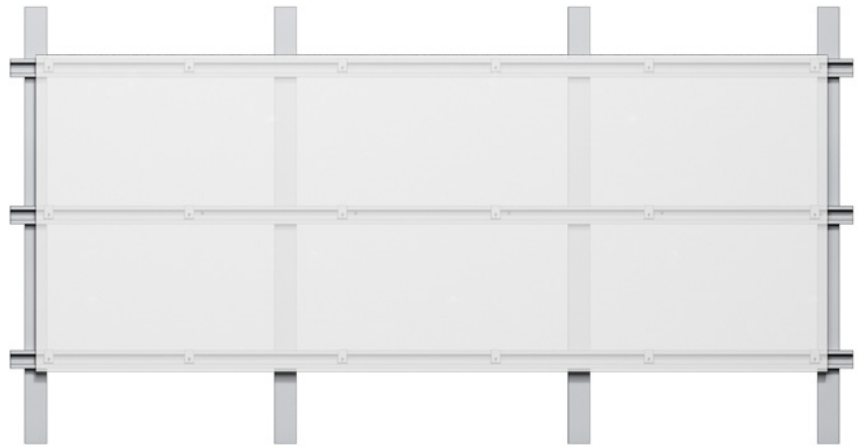

Mounted cross

The alignment of the Hardie® Panel and Hardie® Architectural Panel must be taken into account when verifying stability.

Possible characteristic wind suction load [kN/m²] for panel thickness 11 mm with Hardie™ Panel Conceal

Hardie® Panel and Hardie® Architectural Panel 11 mm facade cladding - with Hardie™ Panel Conceal Anchor & hanger mounted on edge					
fixings per subframe		spacing of subframe [mm]			
Quantity	spacing [mm]	300	400	500	600
11	295	2.53	1.93	1.34	1.13
10	327	2.36	1.79	1.25	1.06
9	368	2.15	1.63	1.15	0.97
8	421	1.88	1.42	1.00	0.85
7	491	1.60	1.20	0.85	0.71
6	589	1.32	0.99	0.70	0.59

Hardie® Panel and Hardie® Architectural Panel 11 mm facade cladding - with Hardie™ Panel Conceal Anchor & hanger mounted cross					
fixings per subframe		spacing of subframe [mm]			
Quantity	spacing [mm]	300	400	500	600
6	224	3.05	2.10	1.78	1.48
5	284	2.49	1.73	1.47	1.22
4	373	2.07	1.43	1.22	1.02
3	560	1.26	0.87	0.74	0.62

Possible characteristic wind suction load [kN/m²] for panel thickness 11 mm with Hardie™ Panel Conceal

Hardie® Panel und Hardie® Architectural Panel 11 mm facade cladding - mit Hardie™ Panel Conceal Anchor & double hanger mounted on edge					
fixings per subframe		spacing of subframe [mm]			
Quantity	spacing [mm]	300	400	500	600
11	295	4.73	3.60	2.51	2.12
10	327	4.41	3.35	2.34	1.98
9	368	4.01	3.04	2.14	1.81
8	421	3.51	2.66	1.87	1.58
7	491	2.99	2.24	1.58	1.33
6	589	2.47	1.86	1.30	1.10

Hardie® Panel and Hardie® Architectural Panel 11 mm facade cladding - with Hardie™ Panel Conceal Anchor & double hanger mounted cross					
fixings per subframe		spacing of subframe [mm]			
Quantity	spacing [mm]	300	400	500	600
6	224	5.69	3.92	3.33	2.76
5	284	4.64	3.23	2.74	2.28
4	373	3.86	2.67	2.28	1.90
3	560	2.36	1.63	1.39	1.16

Possible characteristic wind suction load [kN/m²] for soffits

Hardie® Panel and Hardie® Architectural Panel 11 mm facade cladding - with Hardie™ Panel Conceal Anchor & hanger mounted on edge					
fixings per subframe		spacing of subframe [mm]			
Quantity	spacing [mm]	300	400	500	600
11	295	2.21	1.61	1.03	0.82
10	327	2.05	1.48	0.94	0.75
9	368	1.83	1.31	0.83	0.65
8	421	1.56	1.11	0.69	0.53
7	491	1.29	0.89	0.53	0.40
6	589	1.01	0.68	0.38	0.27

Hardie® Panel and Hardie® Architectural Panel 11 mm facade cladding - with Hardie™ Panel Conceal Anchor & hanger mounted cross					
fixings per subframe		spacing of subframe [mm]			
Quantity	spacing [mm]	300	400	500	600
6	224	2.73	1.78	1.47	1.16
5	284	2.17	1.41	1.15	0.91
4	373	1.75	1.12	0.91	0.70
3	560	0.95	0.56	0.43	0.30

Possible characteristic wind suction load [kN/m²] for soffits

Hardie® Panel und Hardie® Architectural Panel 11 mm facade cladding - mit Hardie™ Panel Conceal Anchor & double hanger mounted on edge					
fixings per subframe		spacing of subframe [mm]			
Quantity	spacing [mm]	300	400	500	600
11	295	4.41	3.29	2.19	1.80
10	327	4.10	3.04	2.03	1.67
9	368	3.70	2.73	1.83	1.49
8	421	3.19	2.34	1.56	1.27
7	491	2.68	1.93	1.27	1.02
6	589	2.16	1.54	0.99	0.79

Hardie® Panel and Hardie® Architectural Panel 11 mm facade cladding - with Hardie™ Panel Conceal Anchor & double hanger mounted cross					
fixings per subframe		spacing of subframe [mm]			
Quantity	spacing [mm]	300	400	500	600
6	224	5.38	3.61	3.01	2.44
5	284	4.33	2.91	2.43	1.97
4	373	3.55	2.36	1.97	1.59
3	560	2.05	1.31	1.07	0.84

Please always check the latest version of the installation guide. The latest version can always be found on the website.

Version Date: 10/2024

© 2024 James Hardie Europe GmbH.
™ and ® denote registered and unregistered trademarks of James Hardie Technology Limited and James Hardie Europe GmbH.

This installation guide/manual sets forth the basic guidelines for Hardie® Panel & Hardie® Architectural Panel installation. It is recommended that installers review national and local building regulation and specific project requirements.

James Hardie Europe GmbH

Bennigsen-Platz 1
40474 Düsseldorf
Germany
www.jameshardie.eu

Contact Information:

Phone: +49 211 54236-200
E-mail: export-jheu@jameshardie.com

har-400-00018/10.24/m